

# Installation Instructions

## Eco 750 mm Horizontal Flue Kit

Part No. 3.023455

60/100 concentric flue for use with  
Alpha Eco condensing boiler

For Technical help or for Service call ...  
**ALPHA HELPLINE Tel: 0844 8718764**  
website: [www.alpha-innovation.co.uk](http://www.alpha-innovation.co.uk)

**Alpha**  
HEATING INNOVATION

Nepicar House, London Road,  
Wrotham Heath, Sevenoaks,  
Kent TN15 7RS



EN 14471

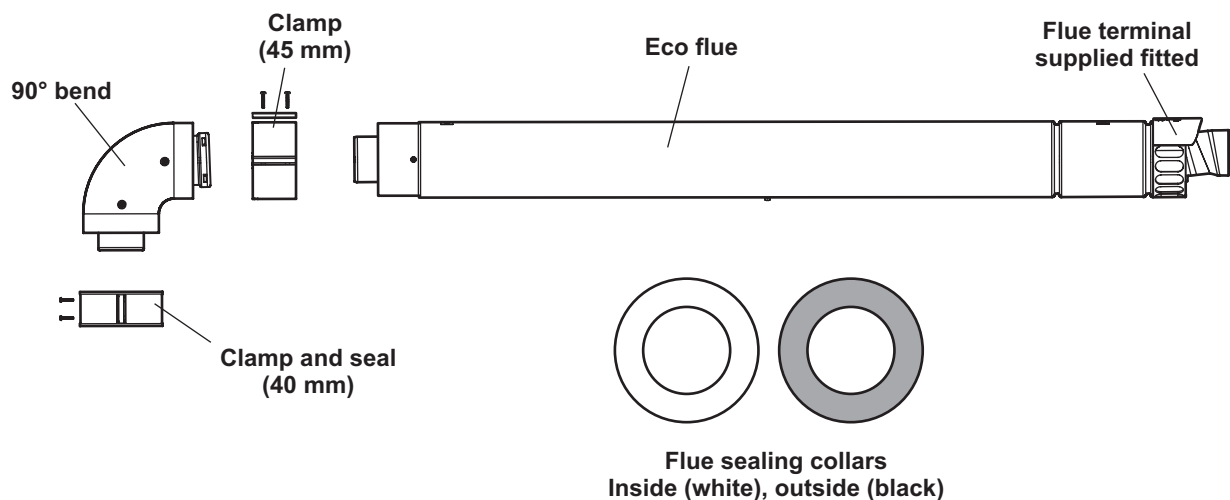

KIT CONTENTS

## 1. GENERAL

**Note:** This flue **MUST ONLY** be used with an Alpha Condensing boiler.

- The Alpha Eco flue is suitable for straight horizontal flues only and can be extended up to a maximum length of 12 m with additional extensions.
- The Eco flue includes a 90° bend, (no separate 90° bend is required).
- Ensure the Eco flue outer duct is installed horizontally (please note that the Eco flue inner duct already has a pre-determined slope towards the boiler for condensate to run back towards the boiler). When extending the flue with flue extensions, the extensions must be installed with a slope downwards towards the boiler by a minimum of 25-30 mm per metre.
- The flue system must be installed in accordance with BS 5440:1.
- The boiler must be installed in accordance with the installation instructions supplied with the Alpha condensing boiler.
- The Eco flue (without extensions) is suitable for use in the flue length ranges shown in Fig. 1.

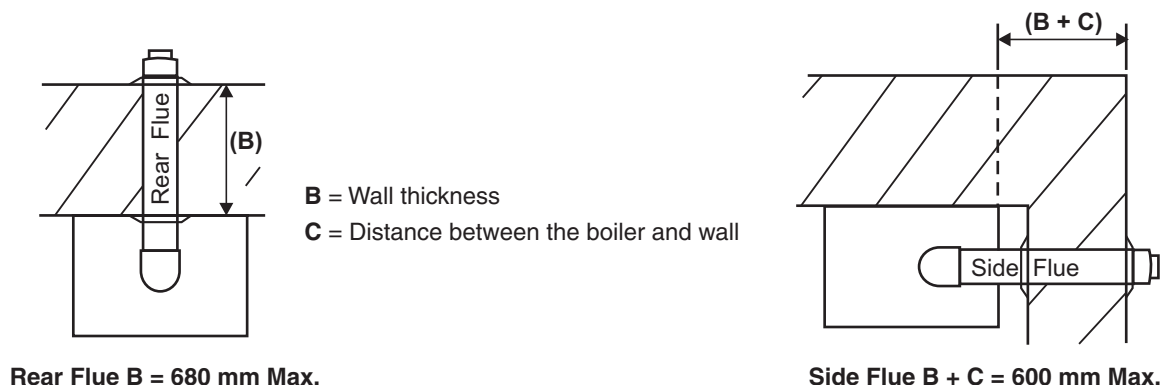

**Fig. 1**

## 2. INSTALL THE BOILER

- Fit the boiler in accordance with the installation instructions supplied with the Alpha condensing boiler.
- Use the template (supplied with the boiler) to mark the flue position and cut a 110 mm diameter flue hole (or use a 107 mm core drill).
 

**Notes:** i. Ensure the hole is cut horizontally.  
 ii. If the Eco flue is being fitted internally, cut a 130 mm diameter flue hole.  
 Refer to Section 3, paragraph b or Section 4.

## 3. FIT THE FLUE

The following procedure applies to fitting an Eco flue to both rear or side exit flue - horizontally only.

**Note:** If extending the Eco flue refer to Section 4.

- Determine the overall length (L) of flue required, (see Fig. 2) as follows:-
 

Rear flue	$L = \text{wall thickness (B)} + 60 \text{ mm}$
Side flue	$L = \text{wall thickness (B)} + \text{distance between boiler and wall (C)} + 145 \text{ mm}$

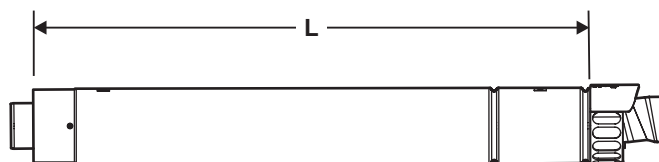

**Fig. 2**

- Pass the flue assembly through the wall (from inside or outside).
 

**Note: Internal fitting** - If there is no access to make good the outside wall, locate the outside (black) flue sealing collar onto the outer duct of the flue immediately before the terminal grille onto the location provided. Push the flue assembly through the 130 mm flue hole, so that the collar completely passes through the wall. Then pull the flue assembly back into the correct position. Visually check that the collar is sealing the outside wall and that it is not restricting any of the openings of the flue terminal.

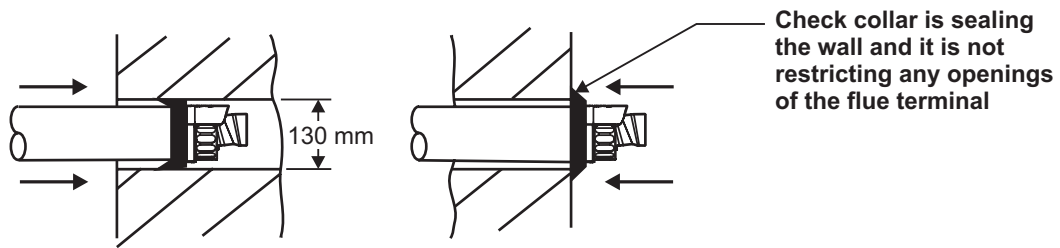

**Fig. 3 - Fitting the flue from inside**

- c. Position the smaller 40 mm clamp (with seal) supplied, over the bend. Fit the bend to the boiler and rotate to the correct position. Secure in position using the clamp. Ensure the clamp is located centrally over both the bend and boiler adaptor.
- d. Fit the inside (white) flue sealing collar over the Eco flue. If it was not previously fitted, fit the outside (black) flue sealing collar onto the flue immediately before the terminal grille onto the location provided.
- e. Slide the larger 45 mm clamp over the outer duct and pull the flue assembly towards the bend, locating the inner duct into the seal joint on the bend. Ensure the labels marked 'TOP' are positioned at the top before securing the flue assembly to the bend with the clamp (two screws) located centrally over the joint.  
**Note:** Check the flue terminal protrudes 140 mm out of the wall and the inner duct of the terminal is positioned correctly (see Fig. 4).
- f. Make good the inside wall by pushing the inside flue sealing collar up to the wall.

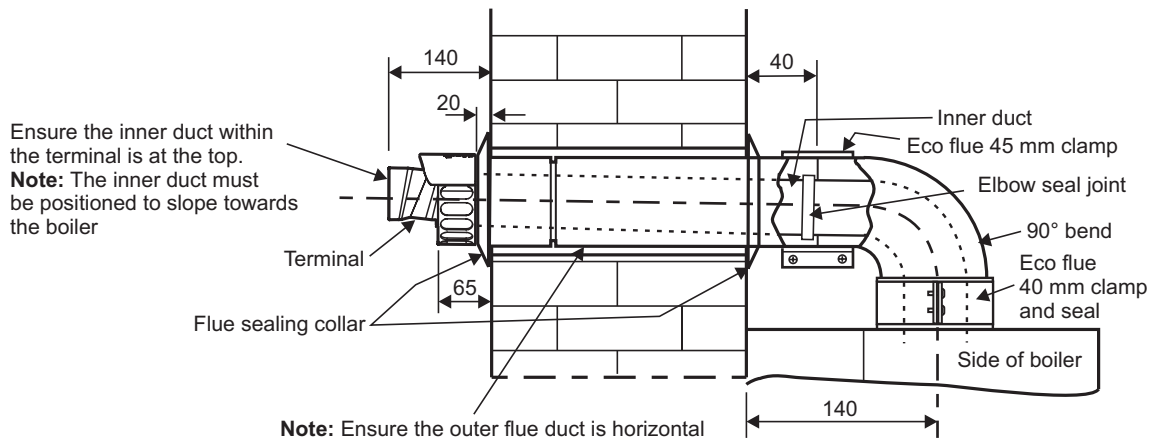

**Fig. 4 - Rear flue**

**4a. REDUCING THE FLUE - Fig. 5**

When the flue length required is less than the minimum stated in Section 1, refer to Fig. 5 below. Cut to the required length so that the inner duct is 20 mm longer than the outer duct.

**Note:** Ensure that all cuts are square and free from burrs.

Once assembled with the components pushed home, the flue is fully sealed.

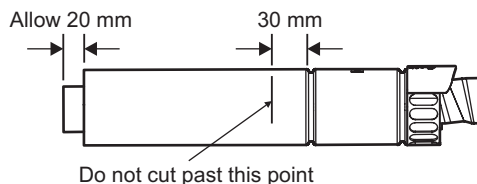

**Fig. 5**

**4b. EXTENDING THE FLUE - Fig. 6**

**Note:** The flue assembly length must not exceed the maximum length stated, including the equivalent lengths of any extensions, bends etc, **boilers must not exceed the maximum of an equivalent horizontal flue length of 12 m.**

Additional support brackets are required when extending the flue. These are available from Alpha, Part no. 6.1000355.

- a. Use the template (supplied with the boiler) to mark the required flue position, ensuring there is the correct slope towards the boiler.

- b. Determine the overall flue length to determine the number of Alpha 750 or 1000 mm flue extensions required.
  - c. Assemble the flue extensions together by locating the inner duct into the seal joint and secure each extension together with the extension clamps supplied. Ensure that the clamps are positioned centrally over the joints.
- Note:** If it is required to cut an extension, **DO NOT** cut the end of the inner duct that incorporates the seal joint. Ensure the inner duct end without the seal joint is cut so that it is 20 mm longer than the outer duct. Ensure that all cuts are square and free from burrs. Once assembled with the components pushed home, the flue is fully sealed.
- d. Fit the Eco flue to the extensions by locating the inner duct into the seal joint and secure with the clamp (three screws), ensuring it is located centrally over the joint.
  - e. Mark the end of the flue assembly 'TOP' where it is connected to the boiler, so that the 'TOP' of the flue terminal is aligned with the 'TOP' at the boiler end of the flue assembly.
  - f. Pass the complete flue assembly through the wall.
  - g. Position the smaller 40 mm clamp (with seal) supplied, over the bend. Fit the bend to the boiler and rotate to the correct position and secure in position. Ensure the seal is located centrally over both the bend and boiler adaptor. If the inside sealing collar (white) is being used to make good the inside wall, then it will need to be fitted before assembling the flue.
  - h. Slide the larger 45 mm clamp over the outer duct and pull the flue assembly towards the bend, locating the inner duct into the seal joint on the bend.
  - i. Secure the flue assembly to the bend with the clamp ensuring it is positioned centrally over the joint, ensuring the 'TOP' marked on the outer duct is positioned at the top.
- Note:** Check the flue terminal protrudes 140 mm out of the wall and that the inner duct of the terminal is positioned correctly, i.e. the inner duct within the terminal is at the top. See Fig. 6.
- j. Make good the outside wall by fitting the outside sealing collar (black) onto the location provided immediately behind the flue terminal grille. Make good the inside wall using the inside sealing collar (white) if required.

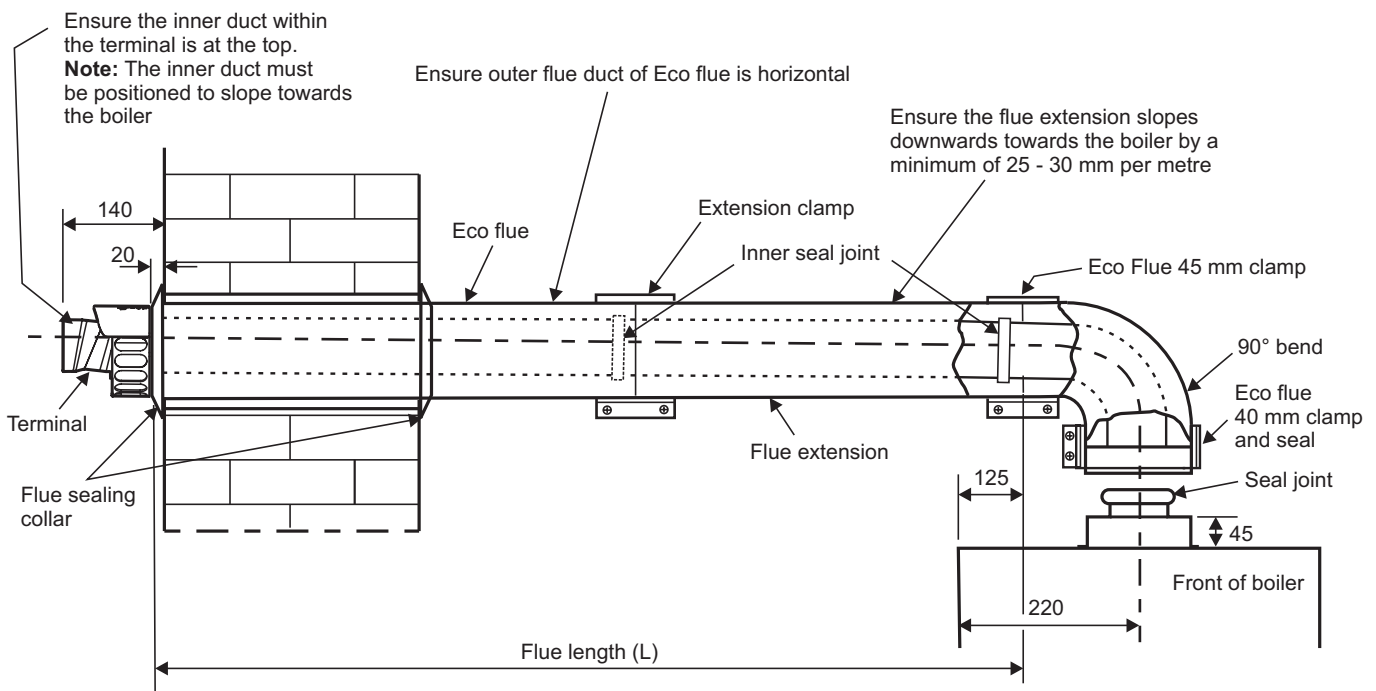

**Fig. 6 - Side flue**

**Alpha**  
HEATING INNOVATION

Alpha Therm Limited.  
Nepicar House, London Road, Wrotham Heath,  
Sevenoaks, Kent TN15 7RS  
Tel: 0844 8718764

email: [info@alpha-innovation.co.uk](mailto:info@alpha-innovation.co.uk)  
website: [www.alpha-innovation.co.uk](http://www.alpha-innovation.co.uk)

*These instructions have been carefully prepared but we reserve the right to alter the specification at any time in the interest of product improvement.  
© Alpha Therm Limited 2012.*